

Single Axis Vertical Reference System

Owner's Manual

PART NUMBER: VRS-E132-1AD



WATSON INDUSTRIES, INC.
3041 MELBY ROAD
EAU CLAIRE, WI 54703

Phone: (715) 839-0628

FAX: (715) 839-8248

Email: support@watson-gyro.com

Table of Contents

Introduction.....	3
Product Description.....	3
Cross Axes Concerns:.....	3
Installation.....	3
Orientation:.....	3
Mounting:.....	3
Environment:.....	4
Power:.....	4
Theory of Operation.....	4
Specifications.....	5
RS-232 Digital Output.....	6
RS-232 Output Format.....	6
RS-232 Input Commands.....	7
Connections.....	8
Dimensions.....	9
WARNING.....	10
Appendix A.....	12
DETERMINING & SETTING OUTPUT CHANNELS.....	12
SETTING OUTPUT FORMAT.....	13
Appendix B.....	14

Watson Industries prides itself on solving customer problems and serving their needs in a timely fashion. This manual is intended to facilitate this goal and to provide written information about your product. We ask that you carefully read this manual. Becoming familiar with the manual will help you understand the product's capabilities and limitations, as well as provide you with a basic understanding of its operation. If, after reading the manual, you require further assistance, do not hesitate to call Watson Industries with your questions and comments.

CAUTION!

Watson Sensors are rugged devices that have been used successfully in a number of harsh environments. The components have been qualified to withstand a mechanical shock of 200g 's or greater, and most enclosures provide an added level of protection. However, dropping a sensor from waist height onto a hard floor can cause a shock level of 600g's. At this level, damage is likely to occur.

Introduction

The Watson Industries Vertical Reference represents a significant advancement in inertial sensor technology. It is a highly accurate and rugged device with many advantages over other types of angular rate and incline-sensing devices. This manual describes operation of the Watson Industries Vertical Reference and also provides useful application information to the system designer.

Product Description

The Watson Industries Vertical Reference System (VRS) is an entirely solid-state sensor that provides exceptional rejection from the adverse effects of inertia and short-term lateral accelerations. It does this through the use of both an accelerometer based vertical reference and an angular rate sensor which is integrated to provide additional information on angular position. It can be a functional replacement for mechanical gyros which are often more expensive and which cannot provide the reliability of a solid-state sensor. Theory of operation is described with more detail on page 4. Size and pinouts are described on page 8. Specifications are shown on page 5.

The Watson Vertical References provide for two types of analog output voltages. One is proportional to angular rate and the other is proportional to angular displacement. Full scale analog outputs produce an output of ± 10 volts dependent upon the direction of angular position or rotation. During rotation, positive voltage output occurs in the direction of the rotational arrow on the case. At horizontal and zero angular rotation rate, both outputs for displacement and rotation rate are near zero. A power supply, providing +10 to +30 Volts DC, is required to operate the unit.

Special options in power supply, output voltage, scale calibration, and special packaging are available as custom units. Pricing and delivery information on custom units is available by contacting the factory.

Cross Axes Concerns:

Turning while banked will cause errors in the pitch angle.

Installation

Orientation:

The base plate of the unit is to be mounted on top of a horizontal surface with the connector toward the forward direction of the vehicle. The VRS drawing, with wire call outs, is located on page 8. The VRS is a rugged device and will withstand harsh environments. However, due attention needs to be paid to the nature of the sensor and its prime function, which is to measure attitude and motion.

Mounting:

The unit has four 0.15" diameter mounting holes for using 6-32 screws. A mounting plate is provided for a flat surface mount. The unit may be adhesively mounted at any of its surfaces. If high shock loads are expected (greater than 20G or repeated shocks greater than 10G), the appropriate shock mounting should be used to prevent damage. Vibration isolation should be used for use in 4G or greater vibration environments.

Environment:

Avoid mounting sites that are subject to significant temperature variation over the duration of the test. Temperature variation will induce significant rate sensor bias drift, which will reflect in poor attitude accuracy.

For shipboard applications, install the sensor near the center of gravity. For all applications, it is preferable to install the device where linear dynamic effects are minimized.

Power:

This unit has an internal regulator to allow operation over a wide voltage input range. Best operation is obtained at either +12 or +24 VDC level, although operation is fully satisfactory down to +10 VDC and up to +30 VDC. The power ground is isolated from the signal ground. Power consumption of the unit is 2.5W. The VRS power system is isolated from the VRS signal system. Internal capacitors are provided to remove a reasonable level of power line noise, however, capacitors should be added for long power line wiring or if noise is induced from other loads on the circuit.

Theory of Operation

In order to obtain an accurate signal in both the short-term and in the long-term, the Vertical Reference relies upon a Watson Industries vibrating structure gyro (VSG) combined with a solid state accelerometer. The position output is derived by integrating the angular rate output. This signal is compared with the output from the accelerometer and the resultant error signal is passed through a long time constant filter and fed back as a bias to the rate sensor. The system is damped by sending a portion of the error directly to the position integrator. By using a long time constant, the effect of the short-term errors in the accelerometer is minimized. Thus, the adverse effects of inertia, damping and short-term lateral accelerations on the pendulum essentially do not show up on the vertical reference output. See Figure 1 for system overview.

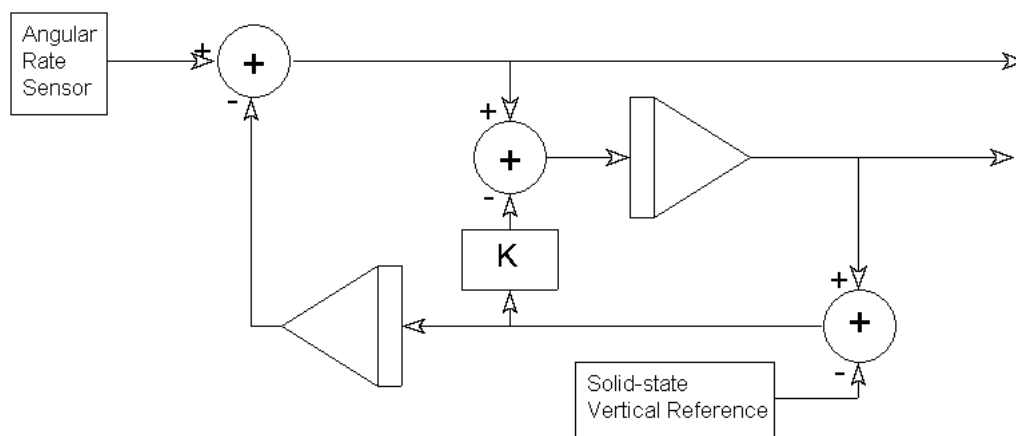

The patented solid-state angular rate sensor has a sensing mechanism consisting of a piezoelectric transducer element mounted to a rigid base in a “cup” configuration. The drive plates induce a resonance in opposite directions. When a rotation occurs, the momentum stored in the vibrating

element causes a precession of vibration energy that is demodulated to accurately depict the rotation rate.

Specifications

Attitude

Range: Elevation	±75° (±50°)	Digital (Analog)
Resolution:	0.02°	Binary mode (14 bit)
Analog Scale Factor:	5°/V	±10V Output
Accuracy: Static	±0.3°	
* Accuracy: Dynamic	±2%	

Angular Rate

Range: Pitch	±100°/sec	
Resolution:	0.01°/sec	Binary mode (14 bit)
Analog Scale Factor:	10°/sec/V	±10V Output
Scale Factor Accuracy:	1%	
Bias: Pitch	< 0.1°/sec (Analog)	±0.02°/sec Binary mode (14 bit)
Non-Linearity	< 0.03%	Full scale range
Bandwidth	20 Hz	
Noise:	< 0.02°/sec rms	

Acceleration

Range: X, Z	±10g	
Resolution:	4mg	
Analog Scale Factor:	1g/V	±10V Output
Scale Factor Accuracy:	1%	
Bias: X, Z	< ±5mg	
Non-Linearity:	< 1%	Full scale range
Bandwidth:	20 Hz	

Environmental

Temperature: Operating	-30°C to +60°C	
Temperature: Storage	-55°C to +85°C	
Vibration: Operating	5g rms	20 Hz to 2 kHz
Vibration: Survival	10g rms	20 Hz to 2 kHz
Shock: Survival	500g	10ms ½ sine wave

Electrical

Frame Rate	71.1 Hz	Maximum
Startup Time: Data	5 sec	
Startup Time: Fully operational	10 sec	
Input Power:	10 to 30VDC	2.5W
Input Current:	210mA @ 12VDC	105mA @ 24VDC
Digital Output	RS-232	
Analog Output	±10VDC	
Analog Output Impedance:	300 Ohm	Per line

Physical

Axis Alignment:	< 0.25°	
Size: Including Mounting Flanges	3.24"W x 5.78"L x 3.25"H	8.2 x 14.7 x 8.3 (cm)
Weight:	21oz (1.3lb)	600g (0.6kg)
Connection: RS-232 / Analog Outputs	9 pin female "D" subminiature	
Connection: Power	9 pin male "D" subminiature	

* Actual accuracy can be calculated as the listed percentage multiplied by the change in value over the entire dynamic maneuver.

- Specifications are subject to change without notice.
- This product may be subject to export restrictions. Please consult the factory.

Analog Output

The VRS features both analog and digital RS-232 outputs. The analog outputs can be found on the 9-pin female Sub-D connector, and feature a full-scale range of $\pm 10\text{VDC}$. The analog output pin map can be found on page 8. The analog outputs are:

1. Elevation (Y) angle on pin 7 has $\pm 10\text{VDC}$ for $\pm 50^\circ$. Scale factor is $5^\circ/\text{V}$.
2. Y angular rate on pin 9 has $\pm 10\text{VDC}$ for $\pm 100^\circ/\text{s}$. Scale factor is $10^\circ/\text{s}/\text{V}$.
3. Signal Ground for both analog signals is on pin 5.

RS-232 Digital Output

The Digital RS-232 outputs can be found on the 9-pin female Sub-D. The Digital output pin map can be found on page 8. The RS-232 signals are reference to the Signal Ground. The digital connections are:

1. RXD is the data receive line – pin 2. The commands are sent to unit on this line.
2. TXD is the data transmit line – pin 3. User Receives data on this line.
3. Signal Ground for RS-232 signals is on pin 5.

RS-232 Output Format

The nominal RS-232 output on the 9-pin female connector consists of a string of decimal ASCII characters sent asynchronously at regular intervals at about 11.85 strings per second. The string is sent at 9600 baud with eight data bits, one stop bit and no parity. The contents of a typical string are formed as follows:

(See Appendix A for information on how to change the data string.)

1. A single letter and a space used to indicate the start of the data string. The letter “I” indicates the start of an inertial data string. The letter “R” indicates the start of a Reference data string. If the letter is in lower case (“i” or “r”), an error over-range condition is indicated (see below).
2. A six character string representing the elevation angle starting with a “+” or a “-“, followed by two digits, a decimal point, one digit and a space for up to ± 75.0 degrees.
3. A six character string representing the Y axis angular rate starting with a “+” or a “-“, followed by two digits, a decimal point, one digit and a space for up to ± 99.9 degrees/second.
4. The string is terminated by a carriage return. There will then be a short interval with no data transmission before the next string begins.

Example:

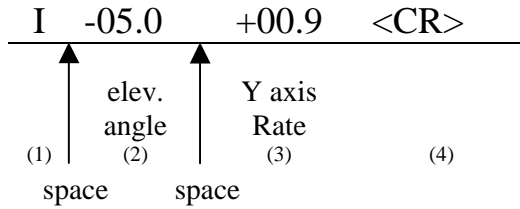

This may be reduced to attitude and heading information to improve the update rate to almost twice the previous rate by using special commands to modify the EEPROM of the unit. More channels are available for output – see Appendix A.

The system is protected from inadvertent write-over of the EEPROM by requiring two spacebar commands during the initialization interval to access the EEPROM or related functions.

The baud rate may be changed from the nominal value of 9600 baud by modifying the default value in the EEPROM of the unit to 38400, 19200, or 4800 baud.

A text header that is sent by the VRS during initializations identifies the unit by part number and by serial number and gives the date of last calibration. Additionally, a line of text characters that identifies the data channel columns is sent if the serial output is set to ASCII decimal. This whole message can be temporarily or permanently suppressed or restored by a “*” command from the interfacing computer.

Data transmission sent by the VRS can also be suppressed or restored by a “+” command from the interfacing computer.

The error overrange condition is indicated by the use of a lower case “i” or “r” when the calculated attitude error exceeds the ranges listed above. Internal functions which require these error values are disabled while the condition exists. The system will continue to operate in an extended time constant mode with a low level of error accumulation until the condition is cleared. Occasional blips of this condition are expected with no detectable affect on the resulting data.

The other output format available is a binary format. The binary format provides generally the same information as the decimal ASCII format, but in a compact binary file format. In this format, there are nominally 9 Bytes sent that represent 4 fourteen bit output channels followed by a carriage return. Again, this may be reduced to attitude information to improve the update rate (in this case the rate would be 71.11 Hz) by using special commands to modify the EEPROM of the unit. This format is for highly experienced users only. Consult the factory for further details.

RS-232 Input Commands

The RS-232 input commands are provided for the purpose of unit test and installation set-up. The same parameters are used as for the output (9600 baud ASCII nominal, or as reset in the units EEPROM). There are eight commands intended for use by the user (others are used at the factory for alignment and calibration).

1. An “R” or “r” will set the outputs (analog and serial) to their Reference Command modes. This mode is used in installation to physically align the unit. Double spacebar at initialization is required for access to this command.
2. An “I” or “i” will clear the Reference Command mode if it had been set by the serial input. This is the default mode at power up and is the normal operating mode. Double spacebar at initialization is required for access to this command.
3. An “F” will disconnect the references from the attitude system and is the Coast Mode Command. This coast mode is used to make the system ignore the references during high maneuvers and brief disturbances. This mode is not intended for use except in brief intervals, since errors will grow geometrically. .
4. A “K” will clear the Coast Mode Command.
5. An “!” will reinitialize the unit. Further, the access to initialization is inhibited such that a spacebar command must be sent within 5 seconds of the “!” command for initialization to be engaged.

There are two output format serial commands: “_” for decimal output and “^” for binary. See second part of Appendix A for more information on change output formats. There are several interface commands as well: “:” will toggle the output to send a frame of data upon receiving any non command character and “+” will toggle the output for no output data. These and other changes are made non-volatile in the unit on EEPROM by keying in the quote (“) character. Double spacebar at initialization is required for access to these commands.

The “&” command calls a menu which allows any of several parameters to be set. These are system time constants, selection of data channels for serial output and baud rate. Double spacebar at initialization is required for access to this command.

The commands “~”, “@”, “#”, “\$”, (“, “), “{“, “}”, “[“, “<”, “>” and “?” are used by the Watson factory to calibrate the unit and should be used only with the assistance of the factory. If an undesired function is called, a “Q”, and sometimes Escape or a Delete will interrupt the command and return to operation with the least disturbance to the system. All other unspecified characters such as carriage return, line feed and space are ignored by the system.

If there are problems with the system “hanging up” during the binary output mode, check for crosstalk between the serial transmit and receive line in your installation. In addition, check to see that the communications program used is not sending an echo. This will not happen in the decimal or hexadecimal modes because command characters recognized by the system are not produced in those modes.

Connections

9 –Pin Male Power Connector	
Pin	Description
1	Power Ground
2	+ 10 to + 30 VDC
3 - 9	No Connection

9 –Pin Female RS-232/Analog Output Connector

Pin	Description
1	No Connection
2	TXD**
3	RXD
4	No Connection
5	Signal Ground
6	No Connection
7	Elevation (Y) Angle Analog Output
8	No Connection
9	Y Angular Rate Analog Output

**User Receives data on this line

The RS-232 serial and analog output connections are referenced to Signal Ground on pin 5.

Dimensions

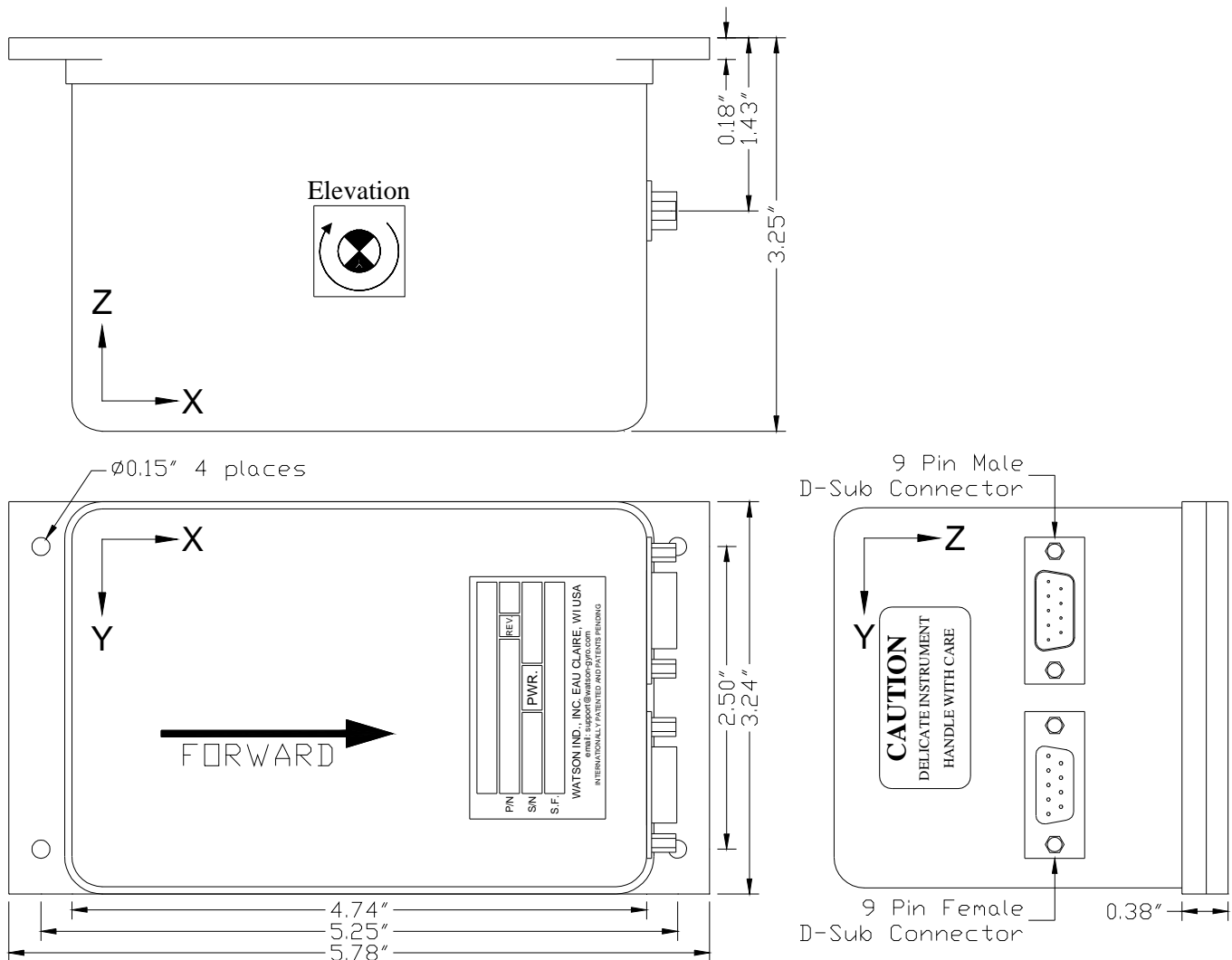

WARNING

Rough handling or dropping of this unit is likely to cause damage. Over-voltage and/or miswiring of this unit will cause damage. This unit should be protected against prolonged exposure to high humidity and/or salt air environments.

DISCLAIMER

The information contained in this manual is believed to be accurate and reliable; however, it is the user's responsibility to test and to determine whether a Watson Industries' product is suitable for a particular use.

Suggestion of uses should not be taken as inducements to infringe upon any patents.

WARRANTY

Watson Industries, Inc. warrants, to the original purchaser, this product to be free from defective material or workmanship for a period of two full years from the date of purchase. Watson Industries' liability under this warranty is limited to repairing or replacing, at Watson Industries' sole discretion, the defective product when returned to the factory, shipping charges prepaid, within two full years from the date of purchase. The warranty described in this paragraph shall be in lieu of any other warranty, express or implied, including but not limited to any implied warranty of merchantability or fitness for a particular purpose.

Excluded from any warranty given by Watson Industries are products that have been subject to abuse, misuse, damage or accident; that have been connected, installed or adjusted contrary to the instructions furnished by seller; or that have been repaired by persons not authorized by Watson Industries.

Watson Industries reserves the right to discontinue models, to change specifications, price or design of this product at any time without notice and without incurring any obligation whatsoever.

The purchaser agrees to assume all liabilities for any damages and/or bodily injury which may result from the use, or misuse, of this product by the purchaser, his employees or agents. The purchaser further agrees that seller shall not be liable in any way for consequential damages resulting from the use of this product.

No agent or representative of Watson Industries is authorized to assume, and Watson Industries will not be bound by any other obligation or representation made in connection with the sale and/or purchase of this product.

PRODUCT LIFE

The maximum expected life of this product is 20 years from the date of purchase. Watson Industries, Inc. recommends the replacement of any product that has exceeded the product life expectation.

SERVICE

Watson Industries, Inc. has no service outlets. All service is performed at the factory. In order to insure prompt service, prior to returning a unit for repair please call, write or fax:

Watson Industries, Inc.
3041 Melby Road
Eau Claire, WI 54703
ATTN: Service Department
Telephone: (715) 839-0628
Fax: (715) 839-8248

All sensors returned under warranty will be repaired (or replaced at the sole option of Watson Industries) at no cost to the customer other than shipping charge from customer to Watson Industries (plus any export and transportation charges outside the United States).

In the case of units not under warranty, a flat repair fee will be charged. This fee can be determined by contacting Watson Industries. Modified units or those subjected to extreme abuse may be returned to the customer unrepaired.

Appendix A

The following outputs are available via the RS-232 serial link. Their full scale ranges are listed for both decimal and binary format.

<u>Inertial Output</u>	<u>Label</u>	<u>Full Scale Decimal</u>	<u>Full Scale Binary</u>
Time Since Reset	TM	65535 seconds	16383 seconds
Elevation	EL	±89.9°	±180°
X Acceleration	XA	±9.99 g	±10 g
Z Acceleration	ZA	±9.99 g	±10 g
Y Angular Rate	YR	±99.9 °/s	±200 °/s
Elevation Pendulum (simulated)	YI	±89.9°	±180°
Temperature	TP	-40° to 88°C	-40° to 88°C (7 bit)
Status Bits	ST	1 byte	1 byte
Flag Bits	FL	1 byte	1 byte

The Flag Bits contains the following information:

- a) Bits 0-2 show the current system time constant, using the following equations:

$$TC=2(\text{Flag Value} + 1)$$

- b) Bit 3 - If set, reference command selected.
c) Bit 4 - If set, Steady Turn Mode Selected
d) Bit 5 - If set, Coast mode is selected.
e) Bit 6 - If set, the analog switches are disabled.

DETERMINING & SETTING OUTPUT CHANNELS

To determine which channels are present.
Hook the unit up to your computers serial port.
Use hyperterminal program to interface with unit.

Turn on unit. Wait for the startup message to appear on display.
Hit the space bar twice within the first 5 seconds of turn on.
Sometimes it takes a few tries to get the hang of this.
Wait for the data string to start transmitting.

Now the unit will take in the keyboard commands.
To determine which channel present, first type '&'.
This will bring up the menu:

```
TYPE IN THE NUMBER OF YOUR SELECTION (OR 'Q' TO QUIT):
 1 = ADJUST TIME CONSTANTS
 2 = SET OUTPUT CHANNELS
 3 = LIST CURRENT OUTPUT CHANNEL SELECTION
 4 = SET NEW BAUD RATE
```

typing in '3' will show which channels are currently active.

To change which channels are output type '&'(this will bring up the menu again)

Now type '2' to set up channels
The following message will appear:

```
TO SET FOR OUTPUT FOR ANY OF THE FOLLOWING DATA ITEMS, PRESS Y  
TO AVOID ANY OF THE FOLLOWING DATA ITEMS, PRESS N  
TO QUIT AND DISREGARD ANY OTHER DATA, PRESS Q  
  
*** DO YOU WANT TO PROCEED? (Y/N/Q)
```

To proceed type 'Y'
Now each channel will come up one at a time
For example:

```
DO YOU WANT OUTPUT OF TIME SINCE RESET?
```

Type 'Y' to output channel , type 'N' to remove channel
When you get to bottom of list, this message will appear:

```
Y = GOBACK, N = INSTALL DATA & QUIT, Q = QUIT  
DO YOU WANT TO TRY TO SET DATA AGAIN?
```

To accept channels type 'N', then hit space bar output data to resume.

To make this channel selection the default the next time you power the unit on type in"" (double quote)

SETTING OUTPUT FORMAT

There are two output formats.
Decimal output - “_” Command.
Binary output – “^” Command.

To change the output format:
Hook the unit up to your computers serial port.
Use hyperterminal program to interface with unit.

Turn on unit. Wait for the startup message to appear on display.
Hit the space bar twice within the first 5 seconds of turn on.
Sometimes it takes a few tries to get the hang of this.
Wait for the data string to start transmitting.

Now the unit will take in the keyboard commands. Press the key Command corresponding to the format you want to switch into. (for example type “_” to change into Decimal Format.)
To make this format selection the default the next time you power the unit on type in"" (double quote.)

Appendix B

Data Word

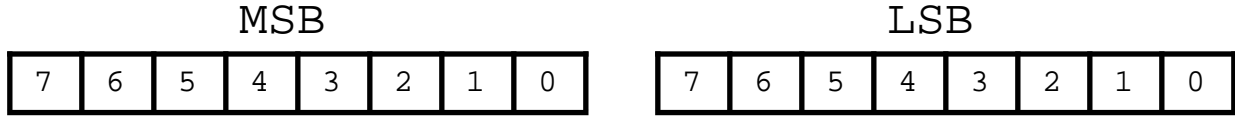

As the data words are received, the LSB is shifted left to shift out the sign bit. The MSB is then connected to the LSB as a 16 bit word. This word is then shifted left to shift out the sign bit. What remains is a signed fractional word with a resolution of 13 bits plus a sign bit.

DATA STREAM



All of the data words have a high sign bit, but the delimiter byte is an ASCII carriage return character which has a low sign bit. The nominal interface settings are:

9600 Baud 8 Bit Data 1 Start Bit 1 Stop Bit No Parity
