

Single Axis Vertical Reference System

Owner's Manual

PART NUMBER: ADS-C132-1A



WATSON INDUSTRIES, INC.
3041 MELBY ROAD
EAU CLAIRE, WI 54703

Phone: (715) 839-0628

FAX: (715) 839-8248

Email: support@watson-gyro.com

Table of Contents

Introduction.....	3
Product Description	3
Installation.....	3
Orientation:	3
Mounting:.....	3
Environment:	3
Power:	4
Theory of Operation	4
Specifications.....	5
Analog Output.....	5
Connections.....	5
Dimensions	6

Watson Industries prides itself on solving customer problems and serving their needs in a timely fashion. This manual is intended to facilitate this goal and to provide written information about your product. We ask that you carefully read this manual. Becoming familiar with the manual will help you understand the product’s capabilities and limitations, as well as provide you with a basic understanding of its operation. If, after reading the manual, you require further assistance, do not hesitate to call Watson Industries with your questions and comments.

CAUTION!

Watson Sensors are rugged devices that have been used successfully in a number of harsh environments. The components have been qualified to withstand a mechanical shock of 500g's and most enclosures provide near that level of protection. However, dropping a sensor from waist height onto a hard floor can cause a shock level of 600g's. At this level, given some resonance, damage is possible.

Introduction

The Watson Industries Vertical Reference represents a significant advancement in inertial sensor technology. It is a highly accurate and rugged device with many advantages over other types of angular rate and incline-sensing devices. This manual describes operation of the Watson Industries Vertical Reference and also provides useful application information to the system designer.

Product Description

The Watson Industries Vertical Reference (ADS) is an entirely solid-state sensor that provides exceptional rejection from the adverse effects of inertia and short-term lateral accelerations. It does this through the use of both a pendulous vertical reference and an angular rate sensor that is integrated to provide additional information on angular position. It can be a functional replacement for mechanical gyros which are often more expensive and which cannot provide the reliability of a solid-state sensor. Theory of operation is described with more detail on page 4. Size and pinouts are described on pages 5-6. Specifications are shown on page 5.

The Watson Vertical References provide for two types of analog output voltages. One is proportional to angular rate and the other is proportional to angular displacement. Full-scale analog outputs produce an output of ± 10 volts dependent upon the direction of angular position or rotation. During rotation, positive voltage output occurs in the direction of the rotational arrow on the case. At horizontal and zero angular rotation rate, both outputs for displacement and rotation rate are near zero. A dual power supply, providing a regulated ± 15 Volts DC, is required to operate the unit.

Special options in power supply, output voltage, scale calibration, and special packaging are available as custom units. Pricing and delivery information on custom units is available by contacting the factory.

Installation

Orientation:

The base plate of the unit is to be mounted on top of a horizontal surface with the connector toward the forward direction of the vehicle. The ADS drawing is located in Figure 2. The ADS is a rugged device and will withstand harsh environments. However, due attention needs to be paid to the nature of the sensor and its prime function, which is to measure attitude and motion.

Mounting:

A mounting plate is provided for a flat surface mount. The unit may be adhesively mounted at any of its surfaces. If high shock loads are expected, greater than 100G or repeated shocks greater than 20G, the appropriate shock mounting should be used to prevent damage. Vibration environments would also require shock mounts or vibration isolation.

Environment:

Avoid mounting sites that are subject to significant temperature variation over the duration of the test. Temperature variation will induce significant rate sensor bias drift, which will reflect in poor attitude accuracy.

For shipboard applications, install the sensor near the center of gravity. For all applications, it is preferable to install the device where linear dynamic effects are minimized.

Power:

The unit requires a regulated ± 15 VDC dual power supply (1.0 Watts). STABLE POWER IS REQUIRED. The system is sensitive to power supply changes.

Theory of Operation

In order to obtain an accurate signal in both the short-term and in the long-term, the Vertical Reference relies upon an Angular rate sensor combined with a solid-state pendulum. The position output is generated by integrating the angular rate output. This signal is compared with the output from the pendulum and the resultant error signal is passed through a long time constant filter and fed back as a bias to the rate sensor. The system is damped by sending a portion of the error directly to the position integrator. By using a long time constant, the effect of the short-term errors in the pendulum is minimized. Thus, the adverse effects of inertia, damping and short-term lateral accelerations on the pendulum essentially do not show up on the vertical reference output. See Figure 1 for system overview.

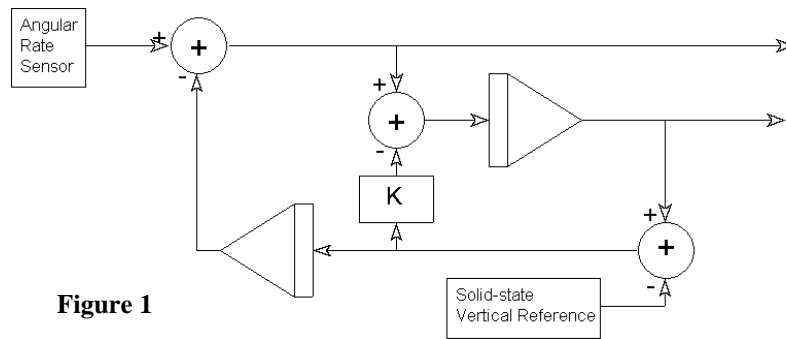

Figure 1

The solid-state angular rate sensor has a sensing mechanism consisting of a piezoelectric transducer element in a “tuning fork” configuration. The two drive elements are resonantly driven in opposite directions. When a rotation occurs, the momentum stored in the vibrating elements causes an out-of-plane bending force that is demodulated to accurately depict the rotation rate.

Since the output of the vertical reference involves the synchronizing of an integrator to a reference, a rotation exceeding either the full scale limits of displacement or angular rate could greatly disturb the synchronization and produce large errors. Returning the unit to a displacement and angular rate within range would allow the unit to again synchronize. Depending on the extent of output saturation, the synchronization will occur in less than sixty (60) seconds.

Specifications

Attitude

Range: Elevation	$\pm 50^\circ$	
Analog Scale Factor:	$5^\circ/\text{V}$	$\pm 10\text{V Output}$
Accuracy: Static	$\pm 0.3^\circ$	
* Accuracy: Dynamic	2%	

Angular Rate

Range: Pitch	$\pm 100^\circ/\text{sec}$	
Analog Scale Factor:	$10^\circ/\text{sec}/\text{V}$	$\pm 10\text{V Output}$
Scale Factor Accuracy:	1%	Constant temperature
Bias: Pitch	$< \pm 1.5^\circ/\text{sec}$	
Non-Linearity	$< 0.05\%$	Full scale range
Bandwidth	50 Hz	

Environmental

Temperature: Operating	-40°C to $+85^\circ\text{C}$	
Temperature: Storage	-55°C to $+85^\circ\text{C}$	
Vibration: Operating	2.5g rms	20 Hz to 2 kHz
Vibration: Survival	10g rms	20 Hz to 2 kHz
Shock: Survival	500g	10ms $\frac{1}{2}$ sine wave

Electrical

Input Power: Positive	12 to 16VDC	0.5W
Input Power: Negative	-12 to -16VDC	0.5W
Input Current:	30mA @ $\pm 15\text{VDC}$	
Analog Output	$\pm 10\text{VDC}$	
Output Impedance:	1000 Ohms	

Physical

Axis Alignment:	$< 2^\circ$	
Size: Single Axis	2.25"W x 4.25"L x 2.50"H	5.7 x 10.8 x 6.4 (cm)
Weight: Single Axis	9oz (0.6lb)	260g (0.3kg)
Connection: Power / Analog Outputs	9 pin male "D" subminiature	

- * Actual accuracy can be calculated as the listed percentage multiplied by the change in value over the entire dynamic maneuver.
- Specifications are subject to change without notice.
- This product may be subject to export restrictions. Please consult the factory.

Analog Output

The analog outputs can be found on the 9-pin male Sub-D connector, and feature a full-scale range of $\pm 10\text{VDC}$. The analog output pin map can be below. The analog outputs are:

1. X Displacement Angle on pin 8 has $\pm 9\text{VDC}$ for $\pm 45^\circ$. Scale factor is $5^\circ/\text{V}$.
2. X Angular Rate on pin 7 has $\pm 10\text{VDC}$ for $\pm 100^\circ/\text{s}$. Scale factor is $10^\circ/\text{s}/\text{V}$.

Connections

9 –Pin Male Connector

Pin	Description
1	Power Ground
2	+15 VDC
3	No Connection
4	No Connection
5	-15 VDC
6	No Connection
7	X Angular Rate Analog Output
8	X Angle Displacement Analog Output
9	No Connection

The analog output connections are referenced to Ground on pin 1.

Dimensions

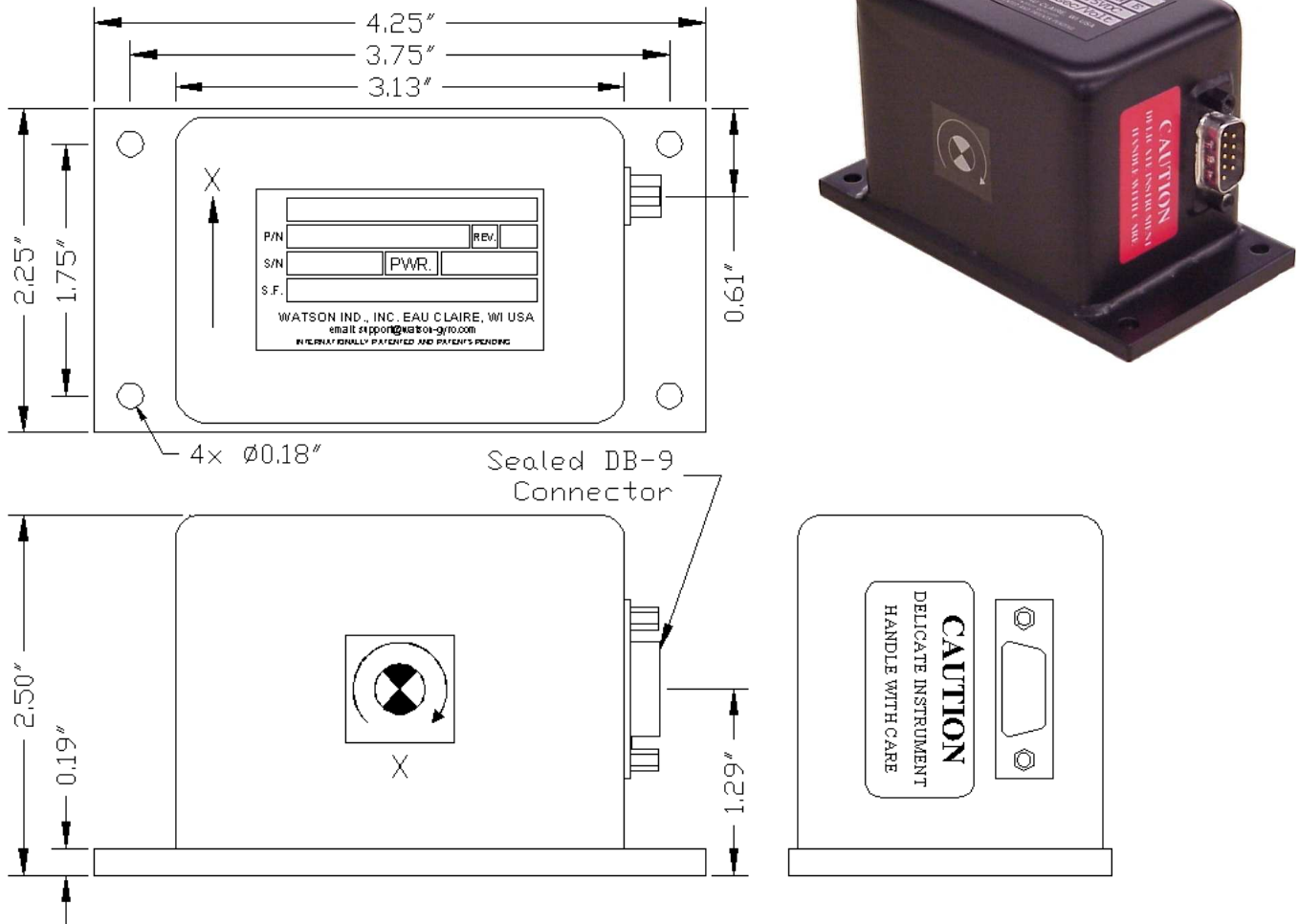

Figure 2: Single Axis ADS-C132-1A

WARNING

Rough handling or dropping of this unit is likely to cause damage. Over-voltage and/or miswiring of this unit will cause damage. This unit should be protected against prolonged exposure to high humidity and/or salt air environments.

DISCLAIMER

The information contained in this manual is believed to be accurate and reliable; however, it is the user's responsibility to test and to determine whether a Watson Industries' product is suitable for a particular use.

Suggestion of uses should not be taken as inducements to infringe upon any patents.

WARRANTY

Watson Industries, Inc. warrants, to the original purchaser, this product to be free from defective material or workmanship for a period of one full year from the date of purchase. Watson Industries' liability under this warranty is limited to repairing or replacing, at Watson Industries' sole discretion, the defective product when returned to the factory, shipping charges prepaid, within one full year from the date of purchase. The warranty described in this paragraph shall be in lieu of any other warranty, express or implied, including but not limited to any implied warranty of merchantability or fitness for a particular purpose.

Excluded from any warranty given by Watson Industries are products that have been subject to abuse, misuse, damage or accident; that have been connected, installed or adjusted contrary to the instructions furnished by seller; or that have been repaired by persons not authorized by Watson Industries.

Watson Industries reserves the right to discontinue models, to change specifications, price or design of this product at any time without notice and without incurring any obligation whatsoever.

The purchaser agrees to assume all liabilities for any damages and/or bodily injury which may result from the use, or misuse, of this product by the purchaser, his employees or agents. The purchaser further agrees that seller shall not be liable in any way for consequential damages resulting from the use of this product.

No agent or representative of Watson Industries is authorized to assume, and Watson Industries will not be bound by any other obligation or representation made in connection with the sale and/or purchase of this product.

SERVICE

Watson Industries, Inc. has no service outlets. All service is performed at the factory. In order to insure prompt service, prior to returning a unit for repair please call, write, fax or email:

Watson Industries, Inc.
3041 Melby Road
Eau Claire, WI 54703
ATTN: Service Department
Telephone: (715) 839-0628 Fax: (715) 839-8248 email: support@watson-gyro.com

All sensors returned under warranty will be repaired (or replaced at the sole option of Watson Industries) at no cost to the customer other than shipping charge from customer to Watson Industries (plus any export and transportation charges outside the United States).

In the case of units not under warranty, a flat repair fee will be charged. This fee can be determined by contacting Watson Industries. Modified units or those subjected to extreme abuse may be returned to the customer unrepaired.