



Dynamic Measurement System with Single Antenna GPS

DMS-SGP01

Description:

The DMS-SGP01 is a miniaturized version of the DMS-EGP01. To allow for a smaller package, this Dynamic Measurement System uses our S series MEMS rate gyro.

The DMS may be used in almost any application where triaxial angular rate and acceleration data is required. The sensor provides both angular rate and acceleration outputs in analog and digital formats. The DMS features six accelerometer outputs. The X, Y, and Z axis outputs represent the accelerations in the plane of the vehicle body, while the second set of three outputs measure the acceleration aligned with an earth-level coordinate system. This allows forward and lateral

acceleration measurements that are essentially free of gravity influences. The triaxial sensor set allows software alignment of sensors, greatly reducing any alignment errors. The serial interface is highly configurable and provides access to almost all operational parameters.

The DMS-SGP01 is used primarily in vehicle applications to integrate the features of a DMS and a velocity sensor into one unit. This sensor is equipped with a single GPS antenna that provides vehicle velocity data to the DMS. This data enhances the unit's performance during highly dynamic maneuvers such as sharp turns and also makes this inertial gyro sensor a more complete system since it does not require velocity information to be supplied from an external sensor.



- Solid State, Strap Down System
- GPS Velocity Data
- Low Cost
- Rugged, High Reliability
- Vibration Resistant
- Analog and RS-232 Serial Outputs
- One Year Limited Warranty
- Engineering Support

Applications:

The DMS-SGP01 is useful in automotive testing and land vehicle dynamics applications. This sensor operates as an enhanced DMS-S605. The GPS antenna provides the DMS with a velocity signal and also transmits heading data while the vehicle is in motion.



Watson Industries, Inc.

3041 Melby Road Eau Claire, Wisconsin 54703 U.S.A
Phone: +1 (715) 839-0628 Fax: +1 (715) 839-8248
e-mail: support@watson-gyro.com Website: www.watson-gyro.com

DMS-SGP01 Specifications

Attitude

Range: Bank	±180°	
Range: Elevation	±75°	
Resolution:	0.02°	Binary mode (14 bit)
Analog Scale Factor:	18°/V	±10V Output
Accuracy: Static	±0.5°	
* Accuracy: Dynamic	±2%	

Heading

Range:	0° - 360°	
Resolution:	0.02°	Binary mode (14 bit)
Analog Scale Factor:	18°/V	±10V Output
Accuracy: Static	±0.5° (±0.05°/sec stationary)	Relative, based on gyro drift
* Accuracy: Dynamic	±2%	±0.1°/sec (without GPS)

Angular Rate

Range: Roll, Pitch, Yaw	±100°/sec	
Resolution:	0.01°/sec	Binary mode (14 bit)
Analog Scale Factor:	10°/sec/V	±10V Output
Scale Factor Accuracy:	2%	
Bias: Roll, Pitch, Yaw	< ±0.3°/sec	
Non-Linearity	< 0.05%	Full scale range
Bandwidth	20 Hz	

Acceleration

Range: X, Y, Z	±10g	
Range: Forward, Lateral, Vertical	±10g	
Resolution:	4mg	
Analog Scale Factor:	1g/V	±10V Output
Scale Factor Accuracy:	1%	
Bias: X, Y, Z	< ±5mg	
Non-Linearity:	< 1%	Full scale range
Bandwidth:	20 Hz	

GPS Positioning

Range: Latitude	±90°	
Range: Longitude	±180°	
Range: Altitude	0 ft to 21500 ft	
Resolution: Latitude, Longitude	0.0000013°	Binary mode (28 bit)
Resolution: Altitude	2 ft	
Accuracy: Latitude, Longitude	5m CEP	

Environmental

Temperature: Operating	-40°C to +85°C	
Temperature: Storage	-55°C to +85°C	
Vibration: Operating	2.5g rms	20 Hz to 2 kHz
Vibration: Survival	10g rms	20 Hz to 2 kHz
Shock: Survival	500g	10ms ½ sine wave

Electrical

Frame Rate	71.1 Hz	Maximum
Startup Time: Data	5 sec	
Startup Time: Fully operational	< 60 sec	Typical
Input Power:	10 to 30VDC	4.4 W
Input Current:	335mA @ 12VDC	185mA @ 24VDC
Input Velocity: (Optional)	±10VDC	Full scale (±400kph)
Digital Output:	RS-232	
Analog Output:	±10VDC	
Output Impedance:	300 Ohm	Per line

Physical

Axis Alignment:	< 0.25°	
Size: Including Mounting Flanges	3.24"W x 5.78"L x 3.50"H	8.2 x 14.7 x 8.9 (cm)
Weight:	27oz (1.7lb)	770g (0.8kg)
Connection: RS-232	9 pin female "D" subminiature	
Connection: Power / Analog Outputs	25 pin male "D" subminiature	
Connection: GPS (Qty 1)	SMA	Antenna cable length: 3.0m

* Using velocity data with GPS mode on.

Actual accuracy can be calculated as the listed percentage multiplied by the change in value over the entire dynamic maneuver.

- Specifications are subject to change without notice.
- This product may be subject to export restrictions. Please consult the factory.



Watson Industries, Inc.

3041 Melby Road Eau Claire, Wisconsin 54703 U.S.A
Phone: +1 (715) 839-0628 Fax: +1 (715) 839-8248
e-mail: support@watson-gyro.com Website: www.watson-gyro.com

**Dimensions:
DMS-SGP01**

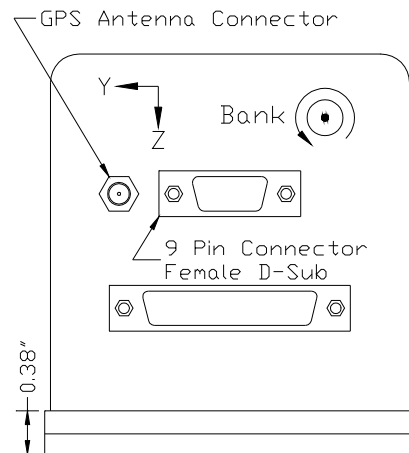
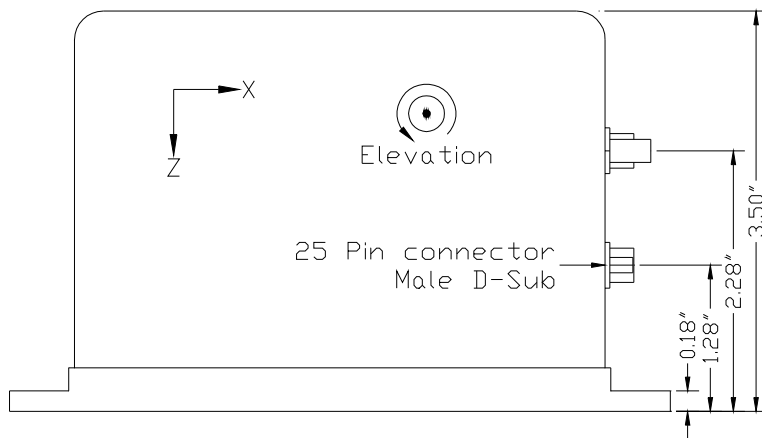
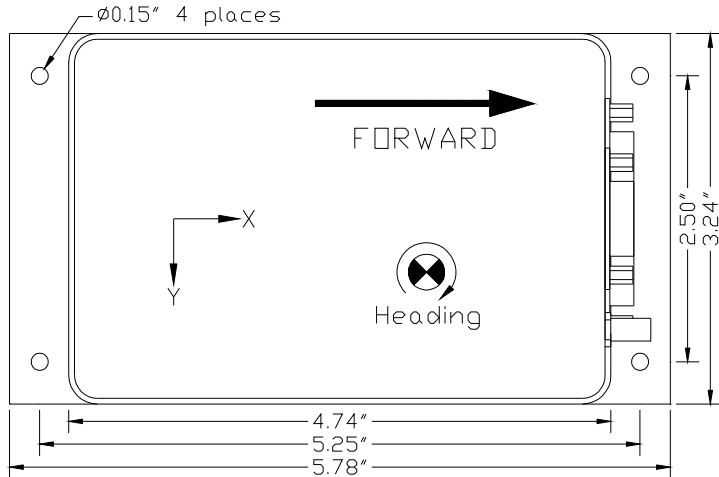

GPS Antenna

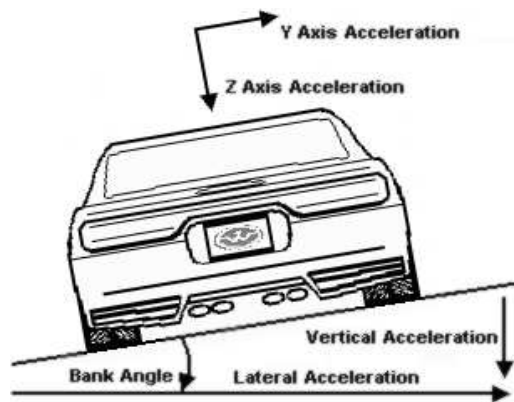
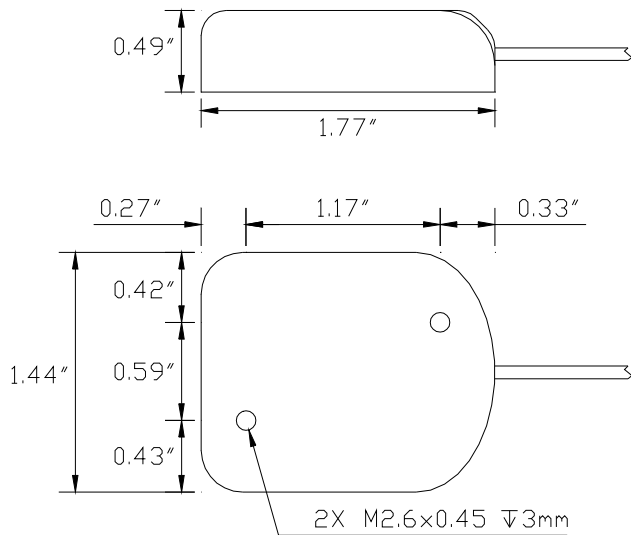

03/10 DAO



Watson Industries, Inc.

3041 Melby Road Eau Claire, Wisconsin 54703 U.S.A
 Phone: +1 (715) 839-0628 Fax: +1 (715) 839-8248
 e-mail: support@watson-gyro.com Website: www.watson-gyro.com