

DYNAMIC MEASUREMENT SYSTEM

OWNER'S MANUAL

**PART NUMBER: DMS-EGP01
GPS Module & Antenna**



**WATSON INDUSTRIES, INC.
3041 MELBY ROAD
EAU CLAIRE, WI 54703**

Phone: (715) 839-0628

FAX: (715) 839-8248

email: support@watson-gyro.com

TABLE OF CONTENTS

1. Introduction	3
2. Product Description.....	3
3. Installation	4
Orientation.....	4
Mounting	4
Environment	4
Power / Connectors.....	4
Calibration	4
4. Operation	4
Initialization.....	4
Normal Operation.....	5
Special Operation Modes	5
Reference Mode.....	5
Free Mode.....	5
Hold Mode.....	6
Control Mode.....	6
Interface.....	6
RS-232 Output Format	6
RS-232 Input Commands	8
Analog Outputs.....	9
Analog Inputs	9
Speed Inputs	10
Output Logic Commands.....	10
Input Logic Commands	10
5. Specifications	11
Figure 1	12
6. Connections / Dimensions.....	13
Figure 2	13
7. Warning	14
8. Appendix A	16
Determining and Setting Output Channels	17
Setting Output Format	18
Setting Heading Mode:.....	18
Setting Velocity Mode:.....	19
9. Appendix B.....	20
10. Appendix C.....	22

Watson Industries prides itself on solving customer problems and serving their needs in a timely fashion. This manual is intended to facilitate this goal and to provide written information about your product. We ask that you carefully read this manual. Becoming familiar with the manual will help you understand the product's capabilities and limitations, as well as provide you with a basic understanding of its operation. If, after reading the manual, you require further assistance, do not hesitate to call Watson Industries with your questions and comments.

CAUTION!

Watson Sensors are rugged devices that have been used successfully in a number of harsh environments. The components have been qualified to withstand a mechanical shock of 200g 's or greater, and most enclosures provide an added level of protection. However, dropping a sensor from waist height onto a hard floor can cause a shock level of 600g's. At this level, damage is likely to occur.

Introduction

The Dynamic Measurement System (DMS) is a solid-state sensor that provides the user with dynamic measurements of angular attitude and angular rate, together with linear acceleration, in three (3) mutually perpendicular planes (see Figure 2). A unique feature is the two sets of acceleration measurements. One set gives sensor acceleration with respect to the sensor mounting face while the other set resolves the motion into horizontal and vertical components, irrespective of the sensor attitude. This allows the earth's gravitational field to be isolated from the measurement of sensor motion.

Product Description

Watson Industries DMS uses solid-state gyros and silicon accelerometers. Interface to the microprocessor is done through a 16-bit A/D converter. The solid state vibrating structure angular rate gyros used in this system provide extremely high reliability, low power consumption, shock resistance and low cost. There are no physical adjustments required by the user. All of the primary transducers are locked into position during manufacture. Adjustments are made with the aid of PC-based maintenance software, which communicates with the DMS via the RS-232 serial connection. Calibration is achieved by using the maintenance software to store data in non-volatile memory within the DMS. The DMS-EGP01 differs from a "standard" DMS with the addition of a GPS antenna and receiver. This allows the DMS to output actual heading instead of relative heading. The GPS receiver also provides a vehicle velocity. This is most useful with wheeled vehicles.

This unit has two modes. A toggle switch on the front of the DMS changes the unit between modes. The first mode, with the switch in the up position, the unit operates like a standard DMS. (See Figure 1). The unit does not use the GPS module, it outputs relative heading, has the ability to take in commands (double space bar mode) and the vehicle speed is an analog input. The heading needs to be in the relative mode & velocity input needs to be in the Analog input mode. (See Appendix A Setting Velocity & Heading Modes)

In the second mode, the DMS uses the GPS module. The switch is in the down position. (See Figure 1). In this mode, the unit outputs actual heading, does not take in commands and the vehicle speed is digital. Please note that the Baud Rate needs to be set to 9600 when using the GPS module (any selectable baud rate is acceptable when the GPS module is not in use). The heading needs to be in the GPS True North mode and velocity input needs to be in the GPS Ground Track mode. (See Appendix A Setting Velocity & Heading Modes)

A vehicle speed input is used to assist in the correction of errors. It is also included in the parameter set that is available for serial output. Although its use is not always required, it is highly recommended that this signal be supplied to the DMS. The unit requires an analog/digital signal. The analog signal is scaled to 40 KPH per volt. The digital signal is from the GPS module. Forward motion should produce a positive signal with respect to signal ground. Many other velocity scale factors can be handled through simple changes in the scale factor stored in the EEPROM in the microprocessor. This can be done with a PC and the assistance of the factory.

Installation

Orientation

The connector face of the unit must point in the forward direction. The DMS drawing, with wire call outs, is located in Figure 2. The DMS is a rugged device and will withstand harsh environments. However, due attention needs to be paid to the nature of the sensor and its prime function, which is to measure attitude and motion.

Mounting

Although a mounting plate is provided for a flat surface mount, the unit may also be adhesively mounted at any of its surfaces. If high shock loads are expected (greater than 20G or repeated shocks greater than 10G), appropriate shock mounting should be used to prevent damage. Vibration isolation should be used if operation in 4G or greater vibration environments is expected. The GPS antenna has a magnetic mount with two M2.6 mounting holes and needs an unobstructed view of the sky to receive signals from GPS satellites.

Environment

Avoid mounting sites that are subject to significant temperature changes over the duration of the test. Temperature variation will induce noticeable rate sensor bias drift, which will result in degraded attitude accuracy.

Power / Connectors

This unit has an internal regulator to allow operation over a wide voltage input range. Best operation is obtained at either 12 or 24 VDC, although operation is fully satisfactory down to 10 VDC and up to 30 VDC. Power draw of the unit is about 5.5 Watts. Internal capacitors are provided to remove a reasonable level of power line noise, however, capacitors should be added for long power line wiring or if noise is induced from other loads on the circuit. The DMS power system is isolated from the DMS signal system. The mating connector for the Power/Analog Output Connector is a 25 Pin female D-Sub. The GPS antenna connector is on the side. For more information on the connectors and pinout of the DMS-EGP01, see Figure 2.

Calibration

The DMS is calibrated at the factory before it is shipped to the user. It is recommended that the unit be returned to the factory annually for evaluation and recalibration.

Operation

Initialization

Ideally, the DMS should be stationary and level when it is turned on. If not, the sensor readings may not be accurate for after initialization. The time required for the initialization process is not the same for every type of DMS, but typically takes 4 to 5 seconds. During this time, a message is sent from the unit via the RS-232 serial link. This message gives information about the DMS such as the full model number, serial number, and software revision. The message can be read by using a terminal program or by using the terminal mode of Watson Industries' communication software.

The DMS can also be "re-initialized" after it has been turned on. This is especially useful if the sensor has been used in severe maneuvers that have over-ranged the angular rate sensors and caused significant errors to accumulate. Sometimes re-initializing the unit will allow for a faster

recovery than waiting for the error correction routines to correct the sensor readings. There are several ways to re-initialize the DMS. For more information, see the Interface section of this manual. Please note that in order to use the GPS mode of this unit, the switch must be in the down position when the unit is initialized or re-initialized (See Figure 1).

Normal Operation

During normal operation, the DMS will output highly accurate inertial data for the user to interpret. This data is transmitted in several different ways. The most common way to acquire data from the DMS is to use the RS-232 serial output. There are two RS-232 output formats: decimal and binary. The exact formatting structure is discussed later in the Interface section of this manual. The DMS generates twelve different data items for output: X, Y, and Z rates, X, Y, and Z accelerations, Bank, Elevation, and Heading, and Forward, Lateral, and Vertical Accelerations. Any combination of these data items can be selected for transmission via the RS-232 serial link. The DMS also has analog outputs (see Interface section) that can be used to send data to the user.

In normal operation, the DMS takes data from its internal rate sensors and integrates in a closed loop system, with the accelerometers as a long-term reference, to generate Bank, Elevation and Heading data. In most cases, these algorithms provide for very stable and accurate output signals; However, the user should be aware that exceeding the normal ranges of the sensors will affect accuracy. For example, while custom DMS units may have differing ranges, the gyros in a typical DMS have a maximum rate of 100°/s. Care should be taken not to exceed this rate because the closed loop system will receive inaccurate data. This will result in errors in the angle output signals.

While this DMS is "all attitude", the accuracy deteriorates rapidly when its forward direction is within about 5 degrees of vertical. Operation for any extended period of time in this orientation is not recommended. If these few operational precautions are observed, the DMS should provide very accurate data for a wide variety of applications.

Special Operation Modes

Reference Mode

This mode is usually used for calibration or diagnostics. When in reference mode, the DMS will output data generated directly from the sensor reference signals rather than as a product of the closed loop integration used for normal operation. This mode provides sensor information similar to normal operation mode with the following differences:

- Bank and Elevation are obtained directly from the accelerometers - no gyro stabilization.
- No heading information is available.
- Angular Rate Sensors are not close-loop bias corrected.

The reference mode can be selected either through the terminal mode, or by an analog logic command. Note that reference mode is never a default setting. It must be re-selected when re-powering the unit.

Free Mode

While in Free Mode, the DMS will output data from the sensors without correction by the references. For example, the Bank Angle data output in Free Mode is calculated directly from the X axis Rate Sensor. In this case, the angle is a direct integration of the roll rate. Free Mode can be used to totally reject effects from dynamic accelerations, but accuracy degrades with time. It is intended for use over periods of a few minutes at a time. This mode provides sensor information similar to normal operation mode with the following differences:

Bank and Elevation are obtained directly from the rate gyros.
No heading information is available.
Angular Rate Sensors are not close-loop bias corrected.

Free mode can be accessed either through terminal mode, or by an analog logic command. Note that free mode is never a default setting. It must be re-selected when re-powering the unit. The user should not enter free mode until after the DMS is initialized and its readings are stable.

Hold Mode

This mode inhibits bias adjustments to the gyros. It is intended for short-term use only since leaving biases uncorrected will allow errors to accumulate over time. The accumulating bias error will result in small attitude errors. Hold mode can provide better performance in highly dynamic environments such as continuous circling over several minutes time. The user should not enter hold mode until after the DMS is initialized and its readings are stable.

Control Mode

In this mode, the DMS will output sensor data normally unless it receives a control mode command. Once a command is received, the DMS will send data in response and await the next command. Using this mode, the user can retrieve the EEPROM map, baud rates, output formats, and many other operational settings of this sensor. Having access to this information makes the Control Mode useful in assisting the factory to remotely troubleshoot the certain operational problems that can occur. For more details, see the RS-232 Input Commands section later in this manual.

Interface

The DMS has analog, logic, and digital interface capabilities.

RS-232 Output Format

The standard RS-232 output consists of a string of decimal ASCII characters sent asynchronously at regular intervals. Nominally, the string is sent at 9600 baud with eight data bits, one stop bit and no parity. The mating connector for the RS-232 is a 9 Pin Male D-Sub. The number of strings sent per second depends on the baud rate and the output format. The maximum rate is 71.11 strings per second. See Appendix A for information on how to change the data string. The contents of a typical string are formed as follows:

1. A single letter and a space used to indicate the start of the data string. The letter “G” indicates the start of an inertial data string with successful GPS data input. The letter “I” indicates the start of an inertial data string with GPS disabled or absence of valid GPS data. The letter “R” indicates the start of a Reference data string. If the letter is in lower case (“g”, “i”, or “r”), an error over-range condition is indicated (see below).
2. A seven character string representing the bank angle starting with a “+” or a “-“, followed by three digits, a decimal point, one digit and a space for up to ± 179.9 degrees.
3. A six character string representing the elevation angle starting with a “+” or a “-“, followed by two digits, a decimal point, one digit and a space for up to ± 89.9 degrees.
4. A six character string representing the heading angle by three digits, a decimal point, one digit and a space for zero to 359.9 degrees.

5. A six character string representing the X axis angular rate starting with a “+” or a “-“, followed by two digits, a decimal point, one digit and a space for up to ± 99.9 degrees/second.
6. A six character string representing the Y axis angular rate starting with a “+” or a “-“, followed by two digits, a decimal point, one digit and a space for up to ± 99.9 degrees/second.
7. A six character string representing the Z axis angular rate starting with a “+” or a “-“, followed by two digits, a decimal point, one digit and a space for up to ± 99.9 degrees/second.
8. A seven character string representing the Forward Velocity starting with a “+” or a “-“, followed by three digits, a decimal point, one digit and a space for up to ± 399.9 Km/Hr.
9. The string is terminated by a carriage return. There will then be a short interval with no data transmission before the next string begins.

Example:

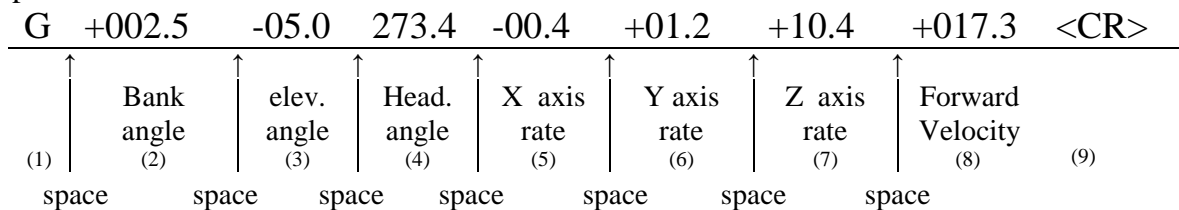

The string transmission rate can be improved by reducing the amount of information (data items) transmitted. The data items transmitted can be changed by using special commands to modify the EEPROM of the unit (see Appendix A). In addition, more channels are available for output (see Appendix A).

The system is protected from inadvertent write-over of the EEPROM by requiring two spacebar commands during the initialization interval to access the EEPROM or related functions.

The baud rate may be changed from the nominal value of 9600 baud by modifying the default value in the EEPROM of the unit to 38.4K, 19.2K, or 4800 baud. Please note that the Baud Rate must be 9600 when using the GPS module.

A text header is sent by the DMS during initializations that identifies the unit by part number and by serial number and gives the date of last calibration. Additionally, a line of text characters that identifies the data channel columns is sent if the serial output is set to ASCII decimal. This whole message can be temporarily or permanently suppressed or restored by a “*” command from the interfacing computer.

Data transmission sent by the DMS can also be suppressed or restored by a “+” command from the interfacing computer.

The error over-range condition is indicated by the use of a lower case “i” or “r” when the calculated attitude or heading error exceeds the ranges listed above. Internal functions that require these error values are disabled while the condition exists. The system will continue to operate in an extended time constant mode with a low level of error accumulation until the condition is cleared. While maneuvering the vehicle, occasional blips of this condition are expected with no detectable effect on the resulting data.

The other output format available is a binary format. In this mode, the unit provides generally the same information as the decimal ASCII format, but in a compact binary message. In this format, there are nominally 13 words sent that represent 6 fourteen-bit output channels followed by a carriage return. Again, the channels may be reduced to improve the update rate by using special commands to modify the EEPROM of the unit. This format is for highly experienced users only. Consult the factory for further details.

RS-232 Input Commands

The RS-232 input commands are provided for the purpose of unit test and installation set-up. Please note these commands are only available when the switch is in the up position. (See Figure 1). The same parameters are used as for the output (9600 baud ASCII nominal, or as reset in the units EEPROM). There are eight commands intended for use by the user (others are used at the factory for alignment and calibration). A double spacebar keyed in during the initialization interval is required for access to most of these commands. The initialization interval is the period of time that the unit takes to send the startup message and start outputting data. The two consecutive spacebar commands must be received during the initialization interval; Any more or less will invalidate the command. Any other characters sent to the unit during this time will also invalidate the command.

1. An “R” or “r” will set the outputs (analog and serial) to their Reference Command modes. This will also disable the logic input Reference Command and Free Mode Command until the next time the unit is powered up. This mode is used in installation to physically align the unit. Double spacebar at initialization is required for access to this command.
2. An “I” or “i” sets the unit to Inertial mode. This is the default mode at power up and is the normal operating mode. Switching to this mode clears the Reference Command mode if it had been set by the serial input. This will also disable the logic input Reference Command and Free Mode Command until the next time the unit is powered up. Double spacebar at initialization is required for access to this command.
3. An “F” or “f” will disconnect the references from the attitude system and is the Free Mode Command. Free mode is used to make the system ignore the references during high maneuvers and brief disturbances. This mode is not intended for use except in brief intervals, since errors will grow geometrically. This will also disable the logic input Reference Command and Free Mode Command until the next time the unit is powered up. Double spacebar at initialization is required for access to this command.
4. An “H” or “h” will remove bias correction from the system and is the Hold Mode Command. This mode is useful in highly dynamic situations that may last for a few minutes. Hold mode should not be used for more than a few minutes, because errors can accumulate. Double spacebar at initialization is required for access to this command.
5. A “K” or “k” will clear the Free Mode Command and Hold Mode Command.
6. An “!” will reinitialize the unit. Further, the access to initialization is inhibited such that a spacebar command must be sent within 2.5 seconds of the “!” command for initialization to be engaged. This command does not require a double space bar at initialization to be in effect.

There are two output format commands: “_” for decimal output and “^” for binary. See second part of Appendix A for more information on changing output formats. There are several interface

Watson Industries, Inc. DMS-EGP01 Rev A 03/05/2010

commands as well: “:” will toggle the output to send a frame of data upon receiving any non-command character and “+” will toggle the output for no output data. These and other changes can be made permanent by keying in the quote (“) character. Double spacebar at initialization is required for access to all of these commands.

The “&” command calls a menu which allows any of several parameters to be set. From this menu, the user can change system time constants, data channels for serial output, heading source, velocity source and baud rate. Double spacebar at initialization is required for access to this command.

The commands “~”, “@”, “#”, “\$”, “(”, “)”, “{”, “}”, “[”, “<”, “>” and “?” are used by the Watson factory to calibrate the unit and should be used only with the assistance of the factory. If an undesired function is called, a “Q”, and sometimes Escape or a Delete will interrupt the command and return to operation with the least disturbance to the system. All other unspecified characters such as carriage return, line feed and space are ignored by the system.

If there are problems with the system “hanging up” during the binary output mode, check for cross-talk between the serial transmit and receive line in your installation. In addition, check to see that the communications program used is not sending an echo. This will not happen in the decimal or hexadecimal modes because command characters recognized by the system are not produced in those modes.

Analog Outputs

Analog signals are output from a 12 bit digital to analog converter with a series resistor to protect the analog buffer amplifier. The output range for all of the analog output channels is ±10 Volts with respect to the common signal ground. The outputs include:

<u>Data</u>	<u>Pin</u>	<u>Range</u>
Bank	14	±180° / ±10V
Elevation	15	±90° / ±5V
Heading	16	0-360° / ±10V
Roll Rate (X Axis)	23	±100°/s / ±10V
Pitch Rate (Y Axis)	24	±100°/s / ±10V
Yaw Rate (Z Axis)	25	±100°/s / ±10V
X Acceleration	17	±10G / ±10V
Y Acceleration	18	±10G / ±10V
Z Acceleration	19	±10G / ±10V
Forward Acceleration	20	±10G / ±10V
Lateral Acceleration	21	±10G / ±10V
Vertical Acceleration	22	±10G / ±10V

Note that the analog switches are disabled after certain serial commands are sent to the unit. This prevents software/hardware switch conflicts.

Analog Inputs

In an effort to make this system more versatile, the DMS allows the user to input analog data that can then be added to the serial data output. This allows the system to act as a data acquisition unit for other vehicle information such as engine RPM, engine temperature, fuel remaining, altitude/depth or any other important data. The four analog user inputs as well as the velocity input

have one megohm input impedance, 16 bit A/D conversion resolution, ± 10 volt input range and have a bandwidth of DC to 25 Hertz.

Speed Inputs

A vehicle speed input is used to assist in the correction of errors. It is also included in the parameter set that is available for serial output. Although its use is not always required, it is highly recommended that this signal be supplied to the DMS. The unit can receive speed information in two formats, an analog or digital signal.

The analog speed input signal is a voltage that is scaled to 40 KPH per volt. Forward motion should produce a positive signal with respect to signal ground. Many other velocity scale factors can be handled through simple changes in the scale factor stored in the EEPROM in the microprocessor. This can be done with a PC and the assistance of the factory.

The digital signal that the DMS can receive is from the GPS module.

Output Logic Commands

Initialization lasts 4 seconds, during which time the "Ready" signal is set low (0v). Once initialization is complete, the "Ready" signal is set high (+5VDC). The ready signal is on pin 9 of the 25 pin connector.

Input Logic Commands

The DMS also has several digital inputs that are all activated by connecting to signal ground. The user should only apply a ground because all the inputs have a pull-up resistor to +5VDC. The pins are as follows:

- a) Initialization - Resets all angle integrators. The unit should be in a non-accelerated condition if this command is given. Leave pin open if not in use. Ground to command.
- b) Reference - An alternate set of sensor information primarily intended as an instrumentation mode. Leave pin open if not in use. Ground to command.
- c) Coast (Free Inertial) – In this mode, the attitude is computed from gyro data only. Free mode is used when extreme accelerations are expected. Leave pin open if not in use. Ground to command.

NOTE: The analog digital inputs are all disabled if any equivalent serial command is sent via RS-232. This is to prevent hardware/software conflicts.

Specifications

Attitude

Range: Bank	±180°	
Range: Elevation	±75°	
Resolution:	0.02°	Binary mode (14 bit)
Analog Scale Factor:	18°/V	±10V Output
Accuracy: Static	±0.25°	
* Accuracy: Dynamic	±2%	

Heading

Range:	0° - 360°	
Resolution:	0.02°	Binary mode (14 bit)
Analog Scale Factor:	18°/V	±10V Output
Accuracy: Static (Relative)	±0.5° (±0.05°/sec stationary)	Relative, based on gyro drift
* Accuracy: Dynamic	±2%	

Angular Rate

Range: Roll, Pitch, Yaw	±100°/sec	
Resolution:	0.01°/sec	Binary mode (14 bit)
Analog Scale Factor:	10°/sec/V	±10V Output
Scale Factor Accuracy:	1%	
Bias: Roll, Pitch, Yaw	< 0.1°/sec (Analog)	±0.02°/sec Binary mode (14 bit)
Non-Linearity	< 0.03%	Full scale range
Bandwidth	20 Hz	
Noise:	< 0.02°/sec rms	

Acceleration

Range: X, Y, Z	±10g	
Range: Forward, Lateral, Vertical	±10g	
Resolution:	4mg	
Analog Scale Factor:	1g/V	±10V Output
Scale Factor Accuracy:	1%	
Bias: X, Y, Z	< ±5mg	
Non-Linearity:	< 1%	Full scale range
Bandwidth:	20 Hz	

GPS Positioning

Range: Latitude	±90°	
Range: Longitude	±180°	
Range: Altitude	0ft to 21500ft	
Resolution: Latitude, Longitude	0.0000013°	Binary mode (28 bit)
Resolution: Altitude	2ft	
Accuracy: Latitude, Longitude	5m CEP	

Environmental

Temperature: Operating	-30°C to +60°C	
Temperature: Storage	-55°C to +85°C	
Vibration: Operating	5g rms	20 Hz to 2 kHz
Vibration: Survival	10g rms	20 Hz to 2 kHz
Shock: Survival	500g	10ms ½ sine wave

Electrical

Frame Rate	71.1 Hz	Maximum
Startup Time: Data	5 sec	
Startup Time: Fully operational	< 60 sec	Typical
Input Power:	10 to 30VDC	5.5W
Input Current:	458mA @ 12VDC	229mA @ 24VDC
Input Velocity: (Optional)	±10VDC	Full scale (±400kph)
Digital Output	RS-232	
Analog Output	±10VDC	



Physical

Axis Alignment:	< 0.1°	
Size: Including Mounting Flanges	6.5"W x 6.5"L x 3.00"H	16.5 x 16.5 x 7.6 (cm)
Weight:	52oz (3.2lb)	1470g (1.5kg)
Connection: RS-232	9 pin female "D" subminiature	
Connection: Power / Analog Outputs	25 pin male "D" subminiature	
Connection: GPS	SMA	Antenna cable length: 3.0m

* Using velocity data with GPS mode on.

Actual accuracy can be calculated as the listed percentage multiplied by the change in value over the entire dynamic maneuver.

- Specifications are subject to change without notice.
- This product may be subject to export restrictions. Please consult the factory.

<p>Up Position - Receive from 9-pin connector This is non-GPS mode. Allows Keyboard commands to be input into the unit.</p>	
<p>Down Position – Receive from GPS module. This is the GPS mode. Keyboard commands are not recognized.</p>	

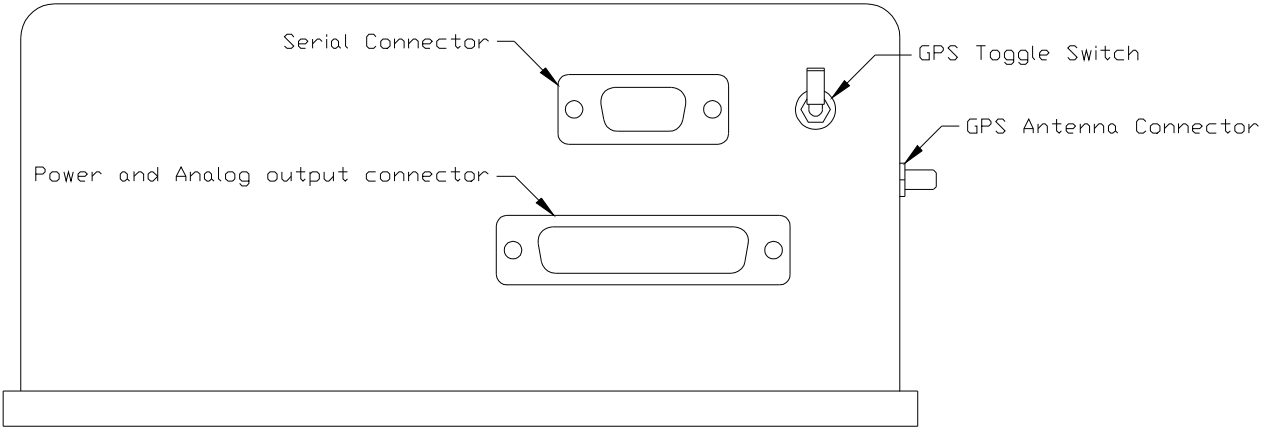

Connections / Dimensions

25 Pin Male D-Sub Power/Analog Output Connector				
Pin	Description		Pin	Description
1	Power Ground		15	Elevation Angle Analog Output
2	+12 or +24 VDC		16	Heading Angle Analog Output
3 - 6	User Inputs 1 - 4		17	X Axis Acceleration Analog Output
7	Not Used		18	Y Axis Acceleration Analog Output
8	Coast Command		19	Z Axis Acceleration Analog Output
9	Ready		20	Forward Acceleration Analog Output
10	Initialization Command		21	Lateral Acceleration Analog Output
11	Velocity Input (option)		22	Vertical Acceleration Analog Output
12	Signal Ground		23	Roll Rate Analog Output
13	Reference Command		24	Pitch Rate Analog Output
14	Bank Angle Analog Output		25	Yaw Rate Analog Output

9 -Pin Female D-Sub RS-232 Serial Communication Connector	
Pin	Description
1	No Connection
2	TXD**
3	RXD
4	Shorted to pin 6
5	Ground
6	Shorted to pin 4
7	Shorted to pin 8
8	Shorted to pin 7
9	No Connection
** The user receives on this line.	

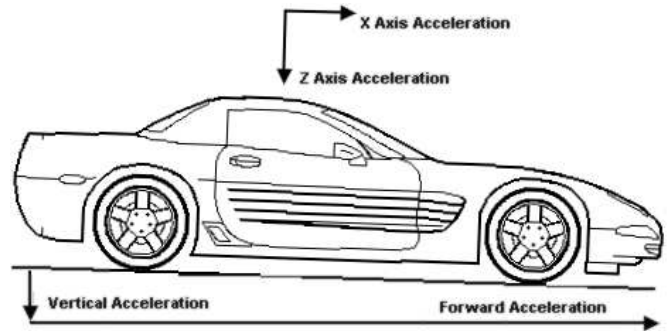
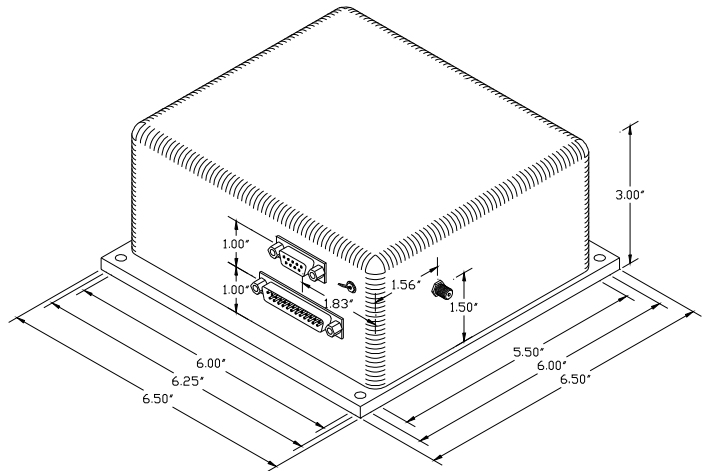
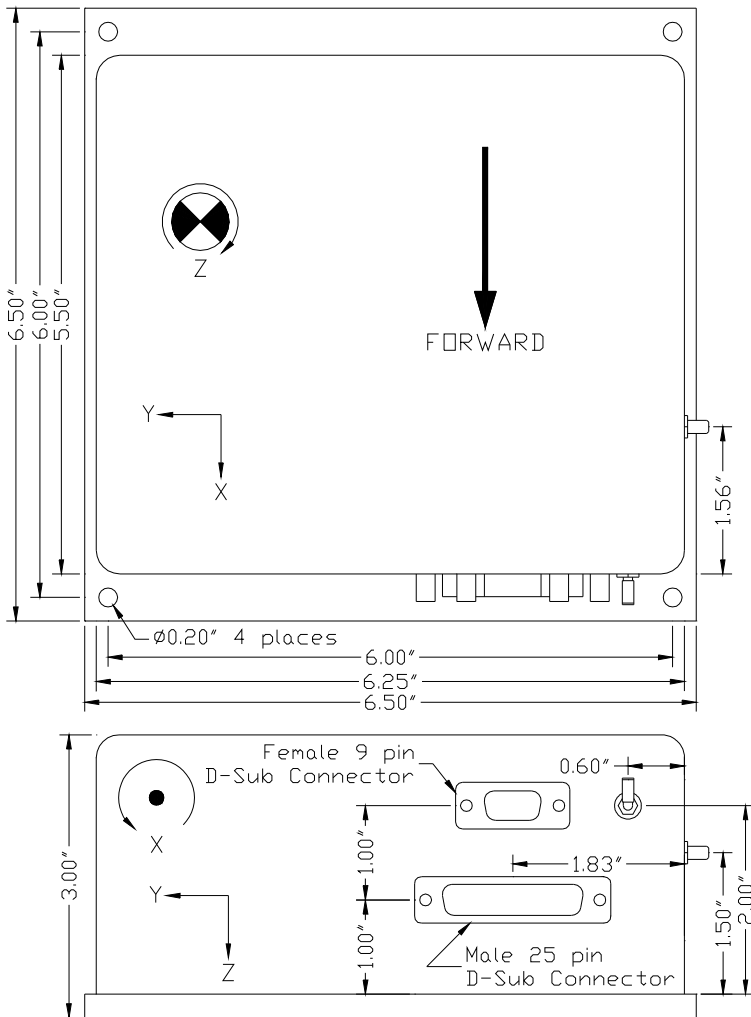

DMS-EGP01
Figure 2

Warning

Rough handling, dropping, or miswiring this unit is likely to cause damage.

DISCLAIMER

The information contained in this manual is believed to be accurate and reliable; however, it is the user's responsibility to test and to determine whether a Watson Industries' product is suitable for a particular use.

Suggestion of uses should not be taken as inducements to infringe upon any patents.

WARRANTY

Watson Industries, Inc. warrants, to the original purchaser, this product to be free from defective material or workmanship for a period of two full years from the date of purchase. Watson Industries' liability under this warranty is limited to repairing or replacing, at Watson Industries' sole discretion, the defective product when returned to the factory, shipping charges prepaid, within two full years from the date of purchase. The warranty described in this paragraph shall be in lieu of any other warranty, express or implied, including but not limited to any implied warranty of merchantability or fitness for a particular purpose.

Excluded from any warranty given by Watson Industries are products that have been subject to abuse, misuse, damage or accident; that have been connected, installed or adjusted contrary to the instructions furnished by seller; or that have been repaired by persons not authorized by Watson Industries.

Watson Industries reserves the right to discontinue models, to change specifications, price or design of this product at any time without notice and without incurring any obligation whatsoever.

The purchaser agrees to assume all liabilities for any damages and/or bodily injury which may result from the use, or misuse, of this product by the purchaser, his employees or agents. The purchaser further agrees that seller shall not be liable in any way for consequential damages resulting from the use of this product.

No agent or representative of Watson Industries is authorized to assume, and Watson Industries will not be bound by any other obligation or representation made in connection with the sale and/or purchase of this product.

PRODUCT LIFE

The maximum expected life of this product is 20 years from the date of purchase. Watson Industries, Inc. recommends the replacement of any product that has exceeded the product life expectation.

SERVICE

Watson Industries, Inc. has no service outlets. All service is performed at the factory. In order to insure prompt service, prior to returning units for repair please call, write or fax:

Watson Industries, Inc.
3041 Melby Road
Eau Claire, WI 54703
ATTN: Service Department
Telephone: (715) 839-0628
Fax: (715) 839-8248
Email: support@watson-gyro.com

All sensors returned under warranty will be repaired (or replaced at the sole option of Watson Industries) at no cost to the customer other than shipping charge from customer to Watson Industries (plus any export and transportation charges outside the United States).

In the case of units not under warranty, a flat repair fee will be charged. This fee can be determined by contacting Watson Industries. Modified units or those subjected to extreme abuse may be returned to the customer unrepared.

Appendix A

The following outputs are available via the RS-232 serial link. Their full scale ranges are listed for both decimal and binary format.

<u>Inertial Output</u>	<u>Full Scale Decimal</u>	<u>Full Scale Binary</u>
Time Since Reset	65,535 seconds	16,383 seconds
Bank Angle	±179.9°	±180°
Elevation Angle	±89.9°	±180°
Heading Angle	0.0 to 359.9°	±180°
X Accelerometer	±9.99 G	±10 G
Y Accelerometer	±9.99 G	±10 G
Z Accelerometer	±9.99 G	±10 G
Forward Acceleration	±9.99 G	±10 G
Lateral Acceleration	±9.99 G	±10 G
Vertical Acceleration	±9.99 G	±10 G
X Angular Rate	±99.9 °/s	±200 °/s
Y Angular Rate	±99.9 °/s	±200 °/s
Z Angular Rate	±99.9 °/s	±200 °/s
Heading Rate	±99.9 °/s	±200 °/s
Corrected Bank Pendulum (simulated)	±179.9°	±180°
Corrected Elevation Pendulum (simulated)	±89.9°	±180°
User Channel 1	±9.99 VDC	±10 VDC
User Channel 2	±9.99 VDC	±10 VDC
User Channel 3	±9.99 VDC	±10 VDC
User Channel 4	±9.99 VDC	±10 VDC
Forward Velocity	±399.9 Km/hr	±400 Km/hr
Temperature	-40° to 88°C	-40° to 88°C (7 bit)
Status Bits	1 byte	1 byte
Flag Bits	1 byte	1 byte

The Flag Bits contains the following information:

Bit	Description
0 to 2	Show the current system time constant, using the following equation: $TC=2(\text{Flag Value} + 1)$
3	If set, Reference Command selected
4	If set, GPS enabled
5	If set, Free Mode selected
6	If set, Analog Switches disabled

The Status Bits contain the following information:

Bit	Description (If Set)
0	Bank Error Flag
1	Elevation Error Flag
2	Heading Error Flag
3	System Error Flag
4	Velocity Error Flag
5	Ready Flag
6	Checksum Error Flag

Determining and Setting Output Channels

To determine which channels are present.
Hook the unit up to your computer's serial port.
Use a terminal program to interface with the unit.
Make sure the switch is in the up position so that unit can receive computer commands.

Turn on unit. Wait for the startup message to appear on display.
Hit the space bar twice within the first 5 seconds of turn on.
Sometimes it takes a few tries to get the hang of this.
Wait for the data string to start transmitting.

Now the unit will take in keyboard commands.
To determine which channel present, first type '&'.
This will bring up the menu:

```
TYPE IN THE NUMBER OF YOUR SELECTION (OR 'Q' TO QUIT):  
  1 = ADJUST TIME CONSTANTS  
  2 = SET OUTPUT CHANNELS  
  3 = LIST CURRENT OUTPUT CHANNEL SELECTION  
  4 = SELECT HEADING SOURCE  
  5 = SELECT VELOCITY SOURCE  
  6 = SET NEW BAUD RATE
```

Typing in '3' will show which channels are currently active.

To change which channels are output type '&'(this will bring up the menu again)

Now type '2' to set up channels
The following message will appear:

```
TO SET FOR OUTPUT FOR ANY OF THE FOLLOWING DATA ITEMS, PRESS Y  
TO AVOID ANY OF THE FOLLOWING DATA ITEMS, PRESS N  
TO QUIT AND DISREGARD ANY OTHER DATA, PRESS Q  
  
*** DO YOU WANT TO PROCEED? (Y/N/Q)
```

To proceed type 'Y'
Now each channel will come up one at a time
For example:

```
DO YOU WANT OUTPUT OF BANK ANGLE?
```

Type 'Y' to output channel, type 'N' to remove channel
When you get to bottom of list, this message will appear:

```
Y = GOBACK, N = INSTALL DATA & QUIT, Q = QUIT  
DO YOU WANT TO TRY TO SET DATA AGAIN?
```

To accept channels type 'N', then hit space bar output data to resume.

To make this channel selection the default the next time you power the unit on type in " (double quote)

Setting Output Format

There are two output formats:

Decimal output – “_” Command.

Binary output – “^” Command.

To change the output format:

Hook the unit up to your computer’s serial port.

Use a terminal program to interface with the unit.

Make sure the switch is in the up position so that unit can receive computer commands.

Turn on unit. Wait for the startup message to appear on display.

Hit the space bar twice within the first 5 seconds of turn on.

Sometimes it takes a few tries to get the hang of this.

Wait for the data string to start transmitting.

Now the unit will take in keyboard commands.

Press the key Command corresponding to the format you want to switch into.

To make this channel selection the default the next time you power the unit on type in " (double quote.)

Setting Heading Mode:

Hook the unit up to your computer’s serial port.

Use a terminal program to interface with the unit.

Make sure the switch is in the up position so that the unit can receive computer commands.

Turn on unit. Wait for the startup message to appear on display.

Hit the space bar twice within the first 5 seconds of turn on.

Sometimes it takes a few tries to get the hang of this.

Wait for the data string to start transmitting.

Now the unit will take in keyboard commands.

To set the heading mode, type in &.

This will bring up the menu:

```
TYPE IN THE NUMBER OF YOUR SELECTION (OR 'Q' TO QUIT):
  1 = ADJUST TIME CONSTANTS
  2 = SET OUTPUT CHANNELS
  3 = LIST CURRENT OUTPUT CHANNEL SELECTION
  4 = SELECT HEADING SOURCE
  5 = SELECT VELOCITY SOURCE
  6 = SET NEW BAUD RATE
```

Typing in 4' will bring up this menu:

```
SELECTION HEADING SOURCE (OR 'Q' TO QUIT):
  1 = GPS TRUE NORTH HEADING
  2 = RELATIVE HEADING
```

To set the heading mode to GPS True North Heading type ‘1’. After setting the unit to this mode, the switch needs to be in the down position. To use this mode, the GPS antenna must be connected to the DMS.

To set the heading mode to Relative Heading type ‘2’. This is the normal DMS mode (non-GPS). In this mode, the GPS antenna does not need to be connected.

To make any of these modes the default the next time you power the unit on type in " (double quote)

Setting Velocity Mode:

Hook the unit up to your computer's serial port.

Use a terminal program to interface with the unit.

Make sure the switch is in the up position so that the unit can receive computer commands.

Turn on unit. Wait for the startup message to appear on display.

Hit the space bar twice within the first 5 seconds of turn on.

Sometimes it takes a few tries to get the hang of this.

Wait for the data string to start transmitting.

Now the unit will take in keyboard commands.

To set the velocity mode, type &.

This will bring up the menu:

```
TYPE IN THE NUMBER OF YOUR SELECTION (OR 'Q' TO QUIT):
  1 = ADJUST TIME CONSTANTS
  2 = SET OUTPUT CHANNELS
  3 = LIST CURRENT OUTPUT CHANNEL SELECTION
  4 = SELECT HEADING SOURCE
  5 = SELECT VELOCITY SOURCE
  6 = SET NEW BAUD RATE
```

Typing in 5' will bring up this menu:

```
SELECTION HEADING SOURCE (OR 'Q' TO QUIT):
  1 = GPS GROUND TRACK VELOCITY
  2 = ANALOG VELOCITY
```

To set to GPS Ground Velocity type '1'. This is the mode when using the GPS module. After this is set up the switch needs to be in the down position. In this mode, the GPS module may still need to be switched on to provide heading data.

To set to Analog Velocity type '2'. This is the normal DMS mode (non-GPS). Make sure that the proper analog velocity signal is applied. In this mode, the GPS module may still need to be switched on to provide heading data.

To make this selection the default the next time you power the unit on type in " (double quote)

Appendix B

Sensor Test Instructions

Tests within this section have been designed to allow the user to verify the correct operation of the sensor without the use of elaborate test equipment other than a means of accurately observing the outputs. The “Hyperterminal” program provides a suitable means of observing the outputs.

B.1 Parameter Exercise Test

After successful initialization, move the sensor in all three axes using both linear and angular motion, making certain each of the measurement parameters responds to the motion.

B.2 Angular Displacement Scale Factor Tests

After successful initialization, place the sensor on a level surface and observe the pitch and roll displacement signals. Place the sensor on a pivot and incline the sensor by a small angle of 6 to 10 degrees in the pitch. A suitable pivot is a 10mm square bar attached to the sensor base plate with adhesive tape. Give the "Reference" command. The signals from the simulated pendulums will be output instead of the normal angular displacement signals. Careful note should be taken of the angles indicated in the reference mode. The sensor should then be tipped on the pivot into the other stable position and the angle again noted.

The procedure of tipping the sensor should be repeated in “Inertial Mode”. The angles obtained should agree with those noted in “Reference Mode”.

Repeat this procedure for the Roll axis. The same pivot may be used, but some care will be needed to avoid exceeding the 100 °/second limit. A more appropriate size of bar would be 5mm square.

B.3 Accelerometer Scale Test

After successful initialization, place the sensor on a level surface and monitor the acceleration outputs. Observe that the X and Y outputs read near zero while the Z axis will read -1G within the accuracy of the sensor.

Set the sensor at a 45° angle to the horizontal in Pitch only. The value of X and Z acceleration should read 0.71G, within the accuracy of the sensor, while the Y acceleration should remain at the level value. The values of Forward, Lateral and Vertical Acceleration should remain at the values when level.

Repeat the test for the roll axis of the sensor. Under this test, Y and Z acceleration will read 0.71G and the X acceleration will retain its value at level.

B.4 Leveled Accelerometer Test

After successful initialization, place the sensor on a level surface, and observe the pitch and roll displacement signals as well as acceleration outputs.

The Forward, Lateral and Vertical outputs should correspond to the X, Y and Z outputs to within the accuracy of the sensor.

Set the sensor at a 45° angle to the horizontal in pitch only, taking care not to move the sensor at an angular rate of more than 100 °/sec.

The Forward, Lateral and Vertical Acceleration outputs should not change from the values at level by more than the accuracy of the sensor.

Move the sensor through a further 45 degrees in pitch such that the baseplate is now vertical, again taking care not to exceed the 100 °/sec limit. The sensor should then be rotated about the vertical and the Yaw output will respond accordingly.

The test should then be repeated for the Roll axis.

Appendix C

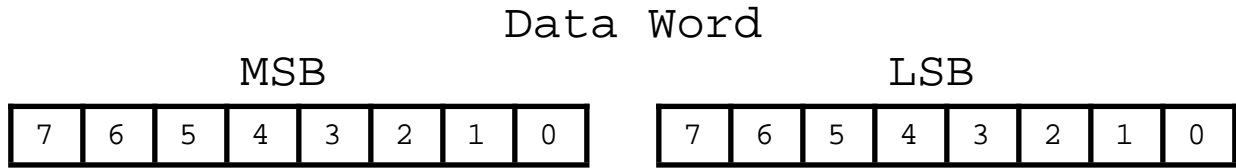

As the data words are received, the LSB is shifted left to shift out the sign bit. The MSB is then connected to the LSB as a 16 bit word. This word is then shifted left to shift out the sign bit. What remains is a signed fractional word with a resolution of 13 bits plus a sign bit.

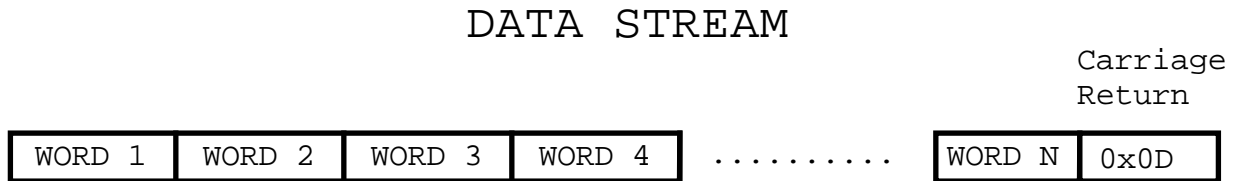

All of the data words have a high sign bit, but the delimiter byte is an ASCII carriage return character, which has a low sign bit. The nominal interface settings are:

9600 Baud
8 Bit Data
1 Start Bit
1 Stop Bit
No Parity
No Handshake